

**FL8T*****Fiberlyte Test Well*****ASSEMBLY INCLUDES**

Cover & Body

Total Weight = 9 lbs (4.1 kg)

(Available in Black or Green)

Fiberlyte is a proven polyester pre-mix with calcium carbonate and polyester resins interlaced with fiberglass and ultra violet inhibitors. Fiberlyte is a durable, state and utility approved, noncombustible material.

- Super lightweight means easier installation and servicing.
- Stronger than precast concrete. Exceeds WUC 3.6 recommendations for 10,000 lb. wheel loading.
- Durable and inert-resistant to heat, cold, and chemicals.
- Won't crack or break during handling, which eliminates loss due to breakage.

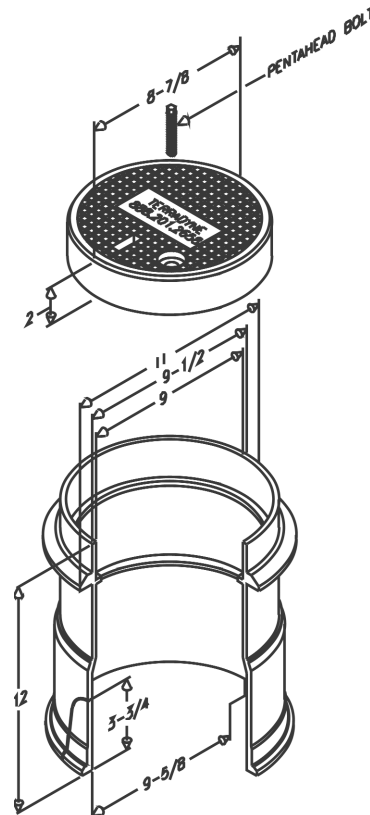
**SPECIFICATIONS**

Flexural Strength: 6,000 PSI

Tensile Strength: 6,000 PSI

Compressive Strength: 20,000 PSI